

Panasonic

エアープラズマ切断トーチ用

純正部品

Genuine Parts for Air Plasma Cutting Torches.

Realized excellent cut off by Panasonic genuine parts.



先進技術を駆使した、エアープラズマ切断トーチの本来の性能・機能を発揮し、高品質の溶接を実現できるのは、洗練された **Panasonic** 純正部品が支えているからです。

Panasonic's advanced automatic air plasma cutting torch are fully operated and functional to perform high quality welding by well studied its genuine parts.

私は、**純正部品の**セールスマンです。

弊社商品をお使いの方はもちろんのこと他メーカーを採用されている方も、是非一度お読み願います。

We welcome you to review this brochure as a potential customer, if you are not currently using Panasonic Welding System.

Panasonic

Introduction

先進技術を駆使したエアープラズマ切断機を送り出して以来、今日に至るまでトップメーカーとして長いご愛顧をいただいております。ご存知の通り、現在、切断機は技術革新が日進月歩で行われその基本性能・品質はもちろんのこと、切断品質が飛躍的に向上し、生産現場の生産性向上に大きく貢献しております。そのベースを支えるのがPanasonic純正部品であります。弊社純正部品は厳選された材質と独自製法に基づき、数多くの実績と伝統に裏づけられ、皆様方のご要望に十二分にご満足していただけるものであります。是非この機会にご採用・ご検討の程お願い申し上げます。

Since we launched our machines using the advanced technology in the world, we have enjoyed the position as the top manufacturer till this day. As you are well aware, the technology has advanced rapidly for cutting machine, not only in basic performance and quality but also the cutting quality has improved greatly to largely contribute to the improvement of the productivity in production sites. All these improvements have been supported by Panasonic's genuine parts. Our genuine parts will fully satisfy your requirements as they are produced by our original manufacturing method using the strictly selected materials on the basis of large accumulation of records and tradition. Please consider the use of our parts.

C O N T E N T S

目次

ア ープラズマ切断トーチ部品名称(代表例)	P1
Air Plasma Cutting Torch Parts Name (Example)	
チップ/電極	P2・3
Tips / Electrode	
シールドカップ(ノズル)/ハンドル(ホルダー)	P4
Shield Cup (Nozzle) / Handle (Holder)	
インシュレータ(ノズルパッキン)/ガイドノズル/オリフィス	P5
Insulator (Nozzle Packing) / Guide Nozzle / Nozzle insulator	
冷却ケーブル(組)/水ホース(組)/ガスホース(組)/ホースカバー	P6
Cooling Cable Ass'y / Water Hose Ass'y / Gas Hose Ass'y / Hose Cover	
トーチスイッチ(組)/スイッチ(組)/制御ケーブル/パイロットケーブル/新製品 PF 形切断トーチ	P7
Torch Switch Ass'y / Switch Ass'y / Control Cable / Pilot Cable / New Model PF Cutting Torch	
トーチボディ(トーチ本体組)	P8
Torch Body (Torch Body Ass'y)	
エアープラズマ切断用(テクノキット)	P9
Air Plasma Cutting Torch	

Air Plasma Cutting Parts Name (examples)

Model PF35A Cutting Torch (Air Cooled)

《YT-03PD2》

Standard parts specifications			
No.	Parts name	No.	Parts name
1	Shield Cup	8	Cooling Cable Ass'y
2	Long Tips	9	Switch Ass'y
3	Long Electrode	10	Control Cable Ass'y
4	Short Tips	11	Hose Cover
5	Short Electrode	12	Nut Cover
6	Torch Body	13	Stop Ring
6-1	Insulator	14	Tip Handle
7	Handle		

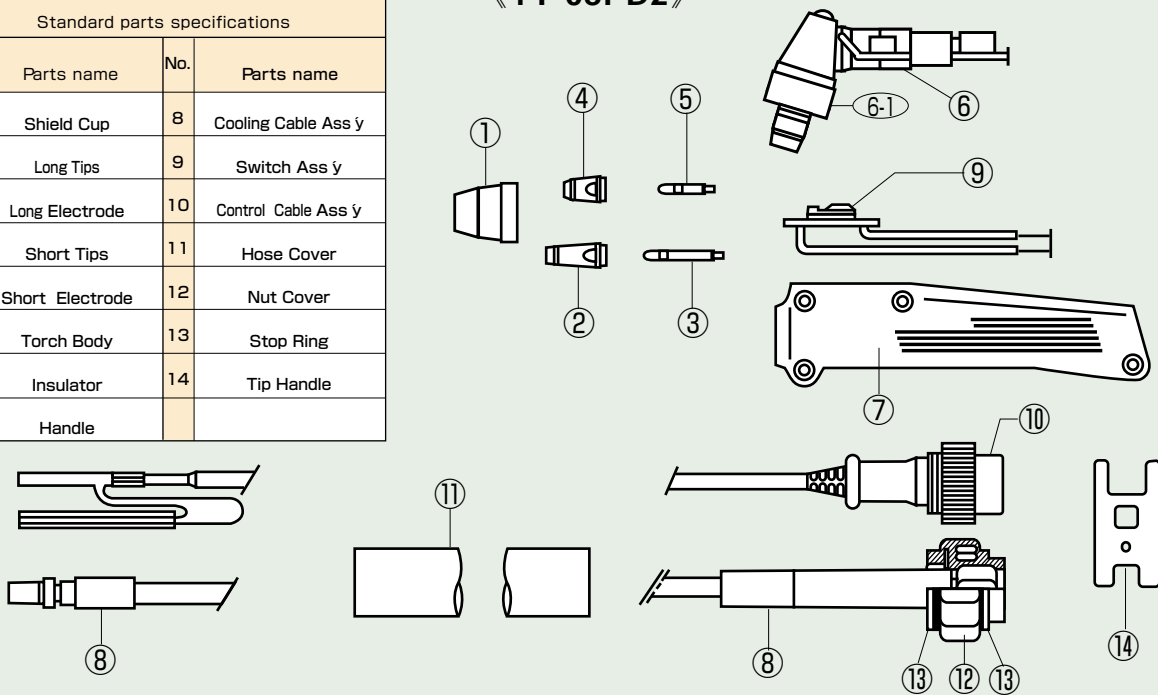

Model PF60A · 80A Cutting Torch (Air Cooled)

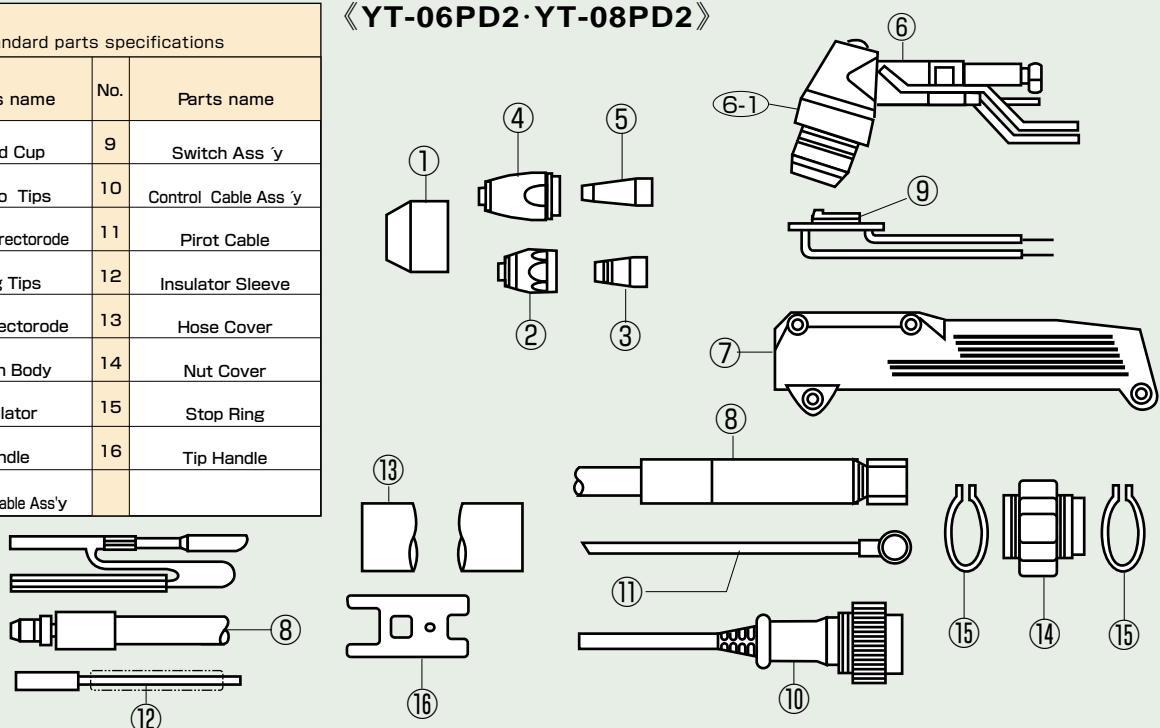

《YT-06PD2·YT-08PD2》

Standard parts specifications			
No.	Parts name	No.	Parts name
1	Shield Cup	9	Switch Ass'y
2	Shorto Tips	10	Control Cable Ass'y
3	Shorto Erectorode	11	Pirot Cable
4	Long Tips	12	Insulator Sleeve
5	Long Erectorode	13	Hose Cover
6	Torrch Body	14	Nut Cover
6-1	Insulator	15	Stop Ring
7	Handle	16	Tip Handle
8	Cooling Cable Ass'y		





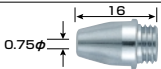

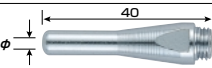
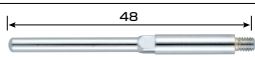
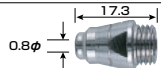
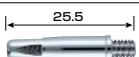
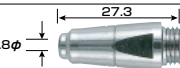
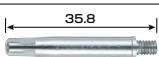

Tips / Electrode

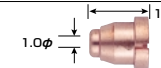

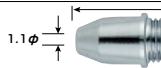

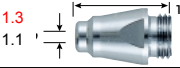
15A用

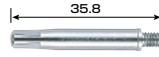
Model	Tips			Electrode		Applicable Torch
	Type	Parts code	Appearance	Parts code	Appearance	
Model 5	Short	TET 00701		TET 01647		YT-015 PC(P)S
	Long	TET 00702		TET 01648		
Model PA2	Short	TET 00029		TET 00006		YT-01 PD(E)2
	Long	TET 00028		TET 00004		



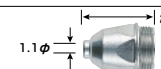

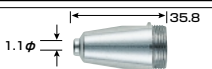

35A用

Model	Tips			Electrode		Applicable Torch
	Type	Parts code	Appearance	Parts code	Appearance	
Model 3	Short	TET 01026		TET 01636		YT-032 PC(P)S
Model 5	Short	TET 01035		TET 02035		YT-035 PC(P)S
Model Gun-260P	Short	TET00022		TET 00006		YT-03 PD1
	Short	TET 00005		TET 00004		YT-03 PE1
Model PF	Long	TET00021		TET 00004		YT-03 PD2
	Long	TET 00003		YT-03 PE2		

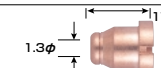
40A用

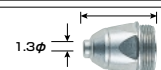
Model	Tips			Electrode		Applicable Torch
	Type	Parts code	Appearance	Parts code	Appearance	
Model 5 Model PF Model PA2	Short	TET 01110		TET 02033		YT-06 PDB2
	Long	TET 01112		TET 02040		YT-065 PC(P)S YT-085 PC(P)S YT-06 PD2 YT-08 PD2

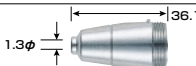
60A用

Model	Tips			Electrode		Applicable Torch
	Type	Parts code	Appearance	Parts code	Appearance	
Model 3	Short	TET 01303		TET 01636		YT-062 PC(P)S
Model 5 Model PF Model PA2	Short	TET 01310		TET 02033		YT-06 PDB2
	Long	TET 01311		TET 02040		YT-065 PC(P)S YT-06 PD(PE)2

Tips / Electrode

80A用

Model	Tips			Electrode		Applicable Torch
	Type	Parts code	Appearance	Parts code	Appearance	
Model 5 Model PF	Short	TET 01512		TET 02033		YT-085 PC(P)S YT-08 PD(PE)2 YT-08 PDA2
	Long	TET 01513		TET 02040		

100A用

Model	Tips			Electrode		Applicable Torch
	Type	Parts code	Appearance	Parts code	Appearance	
Model 3	Short	TET 01702		TET 01636		YT-102 PA(P)S

150A用

Model	Tips				Electrode		Applicable Torch
	Type	Parts code	mmΦ	Appearance	Parts code	Appearance	
Model 5	A Short	TET 02036	2.0		TET 01654		YT-151 PCSWL YT-151 PCPSW
	B Short	TET 01656	1.65				
	C Short	TET 01308	1.35				
	D Short	TET 01106	1.2				
Model PF	F Short	TET 01813	1.85		TET 02042		YT-15 PD(E)W2
	G Short	TET 01688	1.65				
	H Short	TET 01312	1.35				

Shield cup/Nozzle

Model	Model 3			Mode 5・Model PD・Model PF			Remarks
	Current	Parts code	Appearance	Applicable Torch	Parts code	Appearance	
15A	---	---	---	---	TGN 01105		YT-015 PC(P)S
35A	TGN 01655		YT-032 PC(P)S	TGN 01217		YT-010 PD(E)2	3形と5形・PF形・PA2形とは互換性なし
60A 80A	TGN 01927		YT-062 PC(P)S	TGN 02004		YT-06 PDB2 YT-065 PC(P)S YT-06 PD(E)2 YT-085 PC(P)S YT-08 PD(E)2 YT-08 PDA2 YT-15 PD(E)W2	
100A	---	---	YT-102 PA(P)S	---	---	---	
150A	---	---	---	TGN 01703		YT-151 PCSWL YT-151 PCPSW	

Handle / Holder

Model	Model 3		Model 5 Model PA				Model PF			
	Curved / Pencil		Curved		Pencil		Pencil		Curved	
Current	Appearance	Applicable Torch	Appearance	Applicable Torch	Appearance	Applicable Torch	Appearance	Applicable Torch	Appearance	Applicable Torch
15A	---	---		TKG 01101 YT-015 PCS		TKG 01101 YT-015 PCPS		TKG 15104 YT-01 PE2		TKK 00008 YT-010 PD2
35A		TKG 06101 YT-032 PC(P)S		TKG 15104 YT-035 PCS YT-03 PD1		TKG 15104 YT-035 PCPS YT-03 PE1	TKG 15104	TKG 15104 YT-03 PE2		TKK 00008 YT-03 PD2
60A	TKG 06101	TKG 06101 YT-062 PC(P)S		TKG 06101 YT-065 PCS		TKG 06101 YT-06 PCPS		TKG 06101 YT-06 PE2		TKK 00009 YT-06 PD2
80A	---	---	TKG 06101	TKG 06101 YT-085 PCS	TKG 06101	TKG 06101 YT-08 PCPS	TKG 06101	TKG 06101 YT-08 PE2		TKK 00009 YT-08 PD2
80A	---	---	---	---	---	---	---	---		TKK 00010 YT-08 PDA2
100A		TKG 06101 YT-102 PA(P)S	---	---	---	---	---	---	---	---
150A	---	---		TKG 15108 YT-151 PCSWL		TKG 15107 YT-151 PCPSW		TKK 00012 YT-15 PEW2		TKK 00010 YT-15 PDW2

Insulator / Nozzle Paking

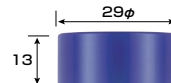
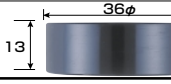
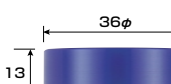
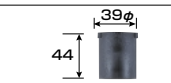
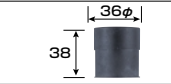
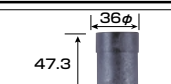
Model	Model 3			Mode 51・Model PD (B)・Model PF			Remarks
Current	Parts code	Appearance	Applicable Torch	Parts code	Appearance	Applicable Torch	
15A	---	---	---	TFQ 01104		YT-015 PC(P)S	
35A	TFQ 03105		YT-032 PC(P)S	TFQ 03106		YT-010 PD(E)2 YT-035 PC(P)S YT-03 PD(E)1 YT-03 PD(E)2	
60A	---	---	---	TFQ 00005		YT-06 PDB2	
	TFQ 06102		YT-062 PC(P)S	TFQ 08102		YT-06 PC(P)S YT-06 PD(E)2	
80A	---	---	---			YT-085 PC(P)S YT-06 PD(E)2	
80A	---	---	---	TFQ 00001		YT-08 PDA2 YT-15 PD(E)W2	注) PF形のみ
100A	TFQ 06102		YT-102 PA(P)S	---	---	---	
150A	---	---	---	TFQ 15108		YT-151 PCSWL	
	---	---	---	TFQ 15107		YT-151 PCPSW	

Guide Nozzle

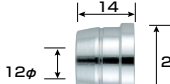
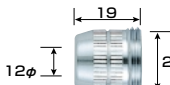
Model	Parts code	Appearance	Applicable Torch	Remarks
Model 3	TGN 01214		YT-032 PC(P)S	5形・PF形には使用
	TGN 01215		YT-062 PC(P)S YT-102 PA(P)S	

Nozzle Insulator

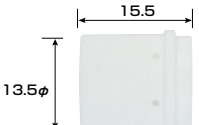
Model	Parts code	Appearance	Applicable Torch	Remarks
Model 3	TGR 00803		YT-032 PC(P)S YT-062 PC(P)S YT-102 PA(P)S	5形・PF形には使用

Cooling Cable Ass'y

Model	Model 3			Mode 5・Model PA・ Mode PA2・Model PF			Remarks
	Parts code	Appearance	Applicable Torch	Parts code	Appearance	Applicable Torch	
15A	—	—	—	TWR 00042		YT-01 PD(E)2	※3形と5形・PA2形・PF形とは互換性なし。 左記※印取扱説明書には()内部品コードで記載されていますが、補修用は()なしの部品コードの部品を出荷させていただきます。
35A	TWR 00028 ※(TWR 06110)		YT-032 PC(P)S	TWR 00027 ※(TWR 00006) ※(TWR 00022)		YT-035 PC(P)S YT-03 PD(PE)1 YT-03 PD(PE)2	
60A			YT-062 PC(P)S	TWR 00028 ※(TWR 06110) ※(TWR 00021)			
80A	—	—	—	TWR 00029 ※(TWR 08104) ※(TWR 00023)		YT-085 PC(P)S YT-08 PD2 YT-08 PE2 YT-08 PDA2	
100A	TWR 00029 ※(TWR 08104)		YT-102 PA(P)S	—	—	—	
150A	—	—	—	TWR 00030 ※(TWR 00024) ※(TWR 15122)		YT-151 PCPSWL YT-151 PCPSW YT-15 PD(E)W2	

Water Hose Ass'y

Model	Parts code	Appearance	Applicable Torch
Model 5	TWW 15101		YT-151 PCPSW YT-151 PCSWL
Model PF	TWW 00008		YT-15 PD(E)W2

Hose Cover

Model	Parts code	Appearance	Applicable Torch
Model 3	TWK 30119 ※(TWK 06101)		YT-032 PC(P)S YT-062 PC(P)S YT-102 PA(P)S
Model 5	TWK 30119 ※(TWK 03101)		YT-01 PD(E)2 YT-035 PC(P)S YT-03 PD(E)1 YT-03 PD(E)2
Model PF	TWK 30119 ※(TWK 06101)		YT-06 PDB2 YT-065 PC(P)S YT-085 PC(P)S YT-151 PCPSWL YT-151 PCSWL YT-06 PD(E)2 YT-08 PD(E)2 YT-08 PDA2
	TWK 00012		YT-15 PD(E)W2

Gas Hose Ass'y







Model	Parts code	Appearance	Applicable Torch
Model 5 Model PF	TWG 15111 ※(TWG 00008)		YT-151 PCPSW YT-151 PCSWL YT-15 PD(E)W2

Torch Switch Ass'y

Model	Model PA2				
Current	Parts code	Appearance	Applicable Torch		Remarks
			Curved	Pencil	
15A	TWU 00111		PA2形	YT-01 PE2	

Model	Model 3・PA 5・PF					
Current	Parts code	Appearance	Applicable Torch		Remarks	
			Curved	Pencil		
15A ∩ 100A	YX 503TC1		3形	YT-032 PCS YT-062 PCS YT-102 PAS	YT-032 PCPS YT-062 PCPS YT-102 PAPS	PF形のカーブタイプ YT-03 PD2 YT-06 PD2 には YT-08 PD2 使用されていません。
			5形	YT-035 PCS YT-065 PCS YT-085 PCS	YT-035 PCPS YT-065 PCPS YT-085 PCPS	
			PA形	YT-03 PD1	YT-03 PE2	
			PF形		YT-03 PE2 YT-06 PE2 YT-08 PE2	

Switch Ass'y/Control Cable





Model	Current	Parts code	Appearance	Parts code	Appearance	Applicable Torch	Remarks
Model 5	150A	TSU 15102		TWU 50132		YT-151 PCSWL	
Model PA2	15A	TSX 00001		TWX 00025		YT-01PD(E)2	注) ①150AペンシルタイプYT-151PCPSWには使用されていません。
Model PF	35A 60A 80A			TWU 50132		YT-03 PD2 YT-06 PD2 YT-08 PD2 YT-06 PDB2	
	80A 150A	TSX 00002			YT-08 PDA2 YT-15 PD(E)W2		

Pilot Cables













Model	Parts code	Appearance	Applicable Torch
Model 3 Model 5 Model PF	TWC 10108		YT-062 PC(P)S YT-102 PA(P)S YT-065 PC(P)S YT-085 PC(P)S YT-151 PCSWL YT-151 PCPSW YT-06 PD(E)2 YT-08 PD(E)2 YT-08 PDA2 YT-15 PD(E)W2 YT-06 PDB2

Torch body (Torch body Ass'y)

Model 3

Model	Curved Type			Pencil Type			Remarks
Current	Parts code	Appearance	Applicable Torch	Parts code	Appearance	Applicable Torch	
35A	TKU 03113		YT-032 PCS	TKU 03114		YT-032 PCPS	Air-Cooling
60A 100A	TKU 06103		YT-062 PCS YT-102 PAS	TKU 06104		YT-062 PCPS YT-102 PAPS	

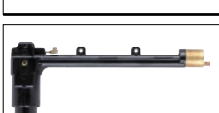
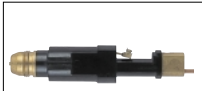
Model 5・PA・PA2・PF

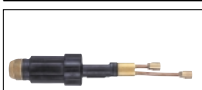
Model	Curved Type			Pencil Type			Remarks
Current	Parts code	Appearance	Applicable Torch	Parts code	Appearance	Applicable Torch	
15A	TKX 00008		YT-01 PD2	TKX 00010		YT-01 PE2	Air-Cooling
15A	TKU 01104		YT-015 PCS	TKU 01106		YT-015 PCPS	
35A	TKX 00004 ※(TKU 00004)		YT-035 PCS YT-03 PD1 YT-03 PD2	TKX 00005 ※(TKU 00006)		YT-035 PCPS YT-03 PE1 YT-03 PE2	
60A	TKX 00009		YT-06 PDB2	—	—	—	
60A 80A	TKU 08103		YT-065 PCS YT-085 PCS YT-06 PD2 YT-08 PD2	TKU 08104		YT-065 PCPS YT-085 PCPS YT-06 PE2 YT-08 PE2	
80A	TKH 00046		YT-08 PDA2	—	—	—	
150A	TKH 15119		YT-151 PCSWL	TKH 15117		YT-151 PCPSW	Water-Cooling
150A	TKH 00044		YT-15PDW2	TKH 00048		YT-15PEW2	

エアープラズマ切断用（テクノキット）

60A・80Aトーチにご利用いただけます。（ただし、電極・チップはショートタイプのみ）

切断性能・能率アップの他 部品の長寿命化にも役立ちます！

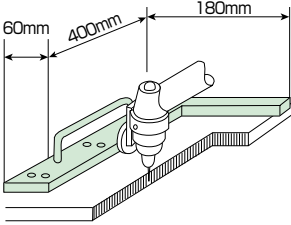
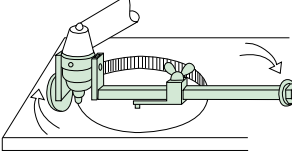
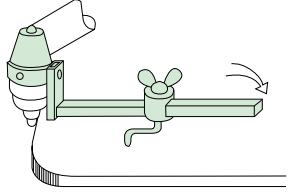
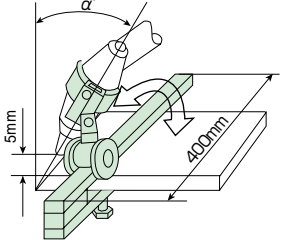
直線治具 YX085PTAS	切断用コンパス YX085PTAC	切断用ミニコンパス YX085PTAM	開先アダプタ YX085PTAK
 <p>トーチを倣わせて切断することにより、美しい直線切断ができます。</p>	 <p>半径14ミリから300ミリの円切りが手軽にできます。</p>	 <p>半径14ミリから150ミリの円切りが手軽にできます。</p>	 <p>直角、30°、45°の開先が簡単に取れます。</p>

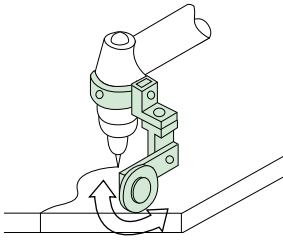
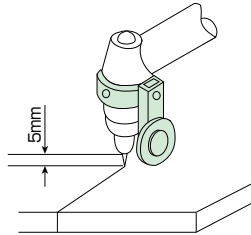
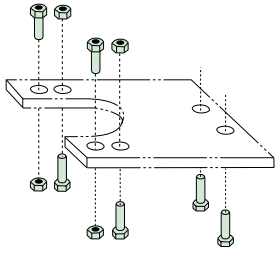
片輪キャスタ YX085PTAF	片輪アダプタ YX085PTAR	絶縁ボルトパーツ YX085PTAB
 <p>車輪がフリーのため、曲がりくねった切断が楽にできます。（円切りは不可）</p>	 <p>手振れがなく走行が安定しますので、中・厚板の切断がスムーズにできます。</p>	 <p>お客様のニーズに合ったゲージに取付けることにより、様々な形切りができます。（形切りゲージ厚は鉄板9mm）</p>

New Model / PF · PA2 Cutting Torch

35A

(Curved Type)



(Pencil Type)



60A・80A

(Curved Type)



(Pencil Type)



80A

(Curved Type)



150A

(Curved Type)



(Pencil Type)



Panasonic
Genuine Parts for Air Plasma Cutting Torches.



ご注意
Safety precautions

●ご使用の際は、取扱説明書をよくお読みのうえ、正しくお使いください。
Before attempting to use any welding product always read the manual thoroughly to ensure correct use.

■アフターサービスに関するお問い合わせは……CS (カスタマーサービス) センターへ

●北海道 (011)222-4834 ●東北 (022)307-6608 ●東部/溶接機 (048)668-7351 ロボット/ (048)668-7361 ●静岡 (054)249-2677 ●中部 (0561)61-3201
●北陸 (076)269-1535 ●西部 (06)6866-8748 ●中四国 (086)805-0045 ●九州 (092)461-7705

お問い合わせは…

松下溶接システム株式会社

〒561-0854 大阪府豊中市稲津町3丁目1番1号
☎大阪 (06) 6866-8556 FAX (06) 6862-1441
ホームページ…<http://www.mie.panasonic.co.jp/mwsc/>



このカタログの内容についてのお問い合わせは、左記にご相談ください。

このカタログの記載内容は
2003年4月現在のものです。

8-010M

■松下溶接システム株式会社/営業所
●北海道 (011)222-4834 ●東北 (022)307-6315 ●東日本 (048)652-0131 ●東京 (03)3697-1108 ●横浜 (042)704-1371
●長野 (0263)26-5144 ●静岡 (054)247-5127 ●中部 (0561)63-9114 ●北陸 (076)269-1245 ●近畿 (06)6866-8535
●兵庫 (078)391-7827 ●西日本 (086)243-7660 ●中国 (082)235-3060 ●四国 (087)879-7566 ●九州 (092)414-3076
■FAテクニカルセンター/各種サンプルの施工・実験を承ります。 ●東部 (03)3697-1421 ●中部 (0561)63-1644 ●大阪 (06)6866-8672

●製品の色は印刷物ですので実際の色と多少異なる場合があります。●製品の定格およびデザインは改善等のため予告なく変更する場合があります。
Specifications and designs subject to change without notice.

宣伝物注文略号

カ・280